

# 产品规格书

## PRODUCT SPECIFICATION

产品名称 (Product Name):

**RE-D705 风冷户外柜**

**(RE-D705 Air-cooling Outdoor Cabinet)**

产品型号 (Product Model No.):

***REMAW07680280C03AV02***

日期 (Date): 25/01/2024

批准 (APPROVER)	审核 (AUDITOR)	编制 (EDITOR)	版本号 (VERSION NO.)

## 目录

1. 概述.....	4
1.1. 设计原则.....	4
1.2. 引用标准.....	4
2. 系统设计.....	4
2.1. 系统组成.....	4
2.2. 系统参数.....	5
3. 电池系统设计及优势说明.....	5
3.1 方案概述.....	5
3.2 方案设计.....	6
3.3 电池系统设计.....	6
3.3.1 电芯设计.....	7
3.3.2 电池 PACK 设计.....	7
3.3.3 电池簇.....	8
3.3.4 电池管理系统.....	9
3.3.5 BMS 系统说明.....	9
3.4 户外柜设计.....	11
3.4.1 户外柜.....	11
3.4.2 散热系统设计.....	11
3.4.3 消防系统设计.....	12
3.4.4 配电系统及接地设计.....	12
3.4.5 储能变流器.....	13
4. 系统一次拓扑图.....	15

## CONTENT (English Version)

1. Overview.....	18
1.1. Design Principle.....	18
1.2. Reference Standard.....	18
2. System Design.....	18
2.1. System Composition.....	18
2.2. System Parameter.....	19
3. Battery System Design and Advantage Description.....	20
3.1 Scheme Overview.....	20
3.2 Scheme Design.....	20
3.3 Battery System Design.....	21
3.3.1 Battery Design.....	21
3.3.2 Battery Pack Design.....	22
3.3.3 Battery Rack.....	23

3.3.4 BMS .....	23
3.3.5 BMS Description .....	24
3.4 Outdoor Cabinet Design .....	26
3.4.1 Outdoor Cabinet .....	26
3.4.2 Cooling System Design .....	27
3.4.3 Fire-fighting System Design .....	28
3.4.4 Distribution System and Ground Connector Design .....	28
3.4.5 Power Conversion System .....	29
4. Primary Topological Graph of System .....	31

## 1. 概述

### 1.1. 设计原则

- (1) 采用成熟的技术和工艺；
- (2) 产品符合相关国家和储能标准的要求；
- (3) 满足产品的技术性能指标；
- (4) 贯彻标准化、模块化、通用化的设计原则，确保产品的通用性和互换性。

### 1.2. 引用标准

GB/T 36276-2018	电力储能用锂离子电池
GB/T 36558-2018	电力系统电化学储能系统通用技术条件
GB/T 34131-2023	电力储能用电池管理系统

## 2. 系统设计

### 2.1. 系统组成

根据产品设计需求，系统由 100kW 逆变器，215kWh 电池簇，5kW 空调，气溶胶消防系统构成，另配有防雷、水浸保护。可实现削峰填谷、需量控制、防逆流功能。

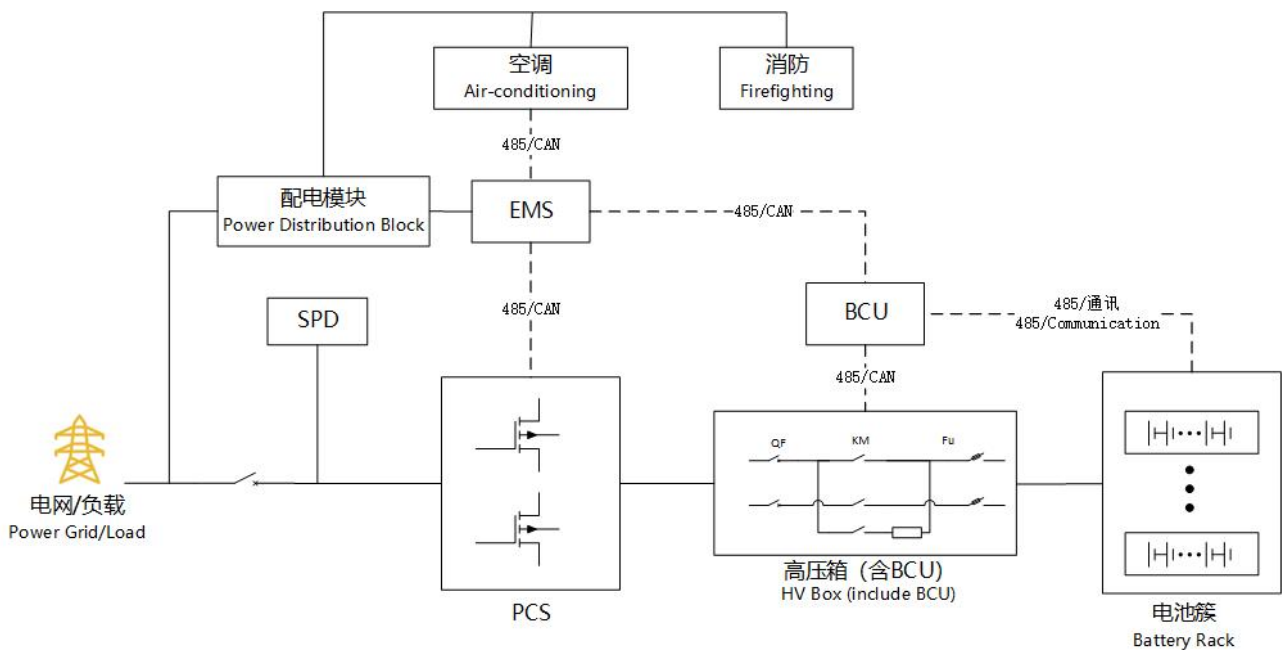

## 2.2. 系统参数

直流参数	系统容量	215kWh
	电芯容量	280Ah (LFP)
	系统配置	1P240S
	额定电压	768VDC
	直流电压范围	672VDC~864VDC
	充放电倍率	0.5P
交流参数	额定功率	100kW
	额定电压	380V, -15%~10%
	接入方式	3P4W+PE
	额定频率	50/60Hz
	功率因数	0.8cap~0.8ind
	Thdi	≤3% (额定功率)
效率		最大 98.5%
保护功能	交流侧	塑壳断路器
	直流侧	隔离开关+熔断器
	消防	气溶胶+水消防
环境条件	工作温度	-25~60°C (> 45°C降额)
	海拔	≤2000m
	相对湿度	0~100%
物理特性	重量	~2t
	尺寸 (长*宽*高)	~1170mm*1420mm*2365mm
	防护等级	IP54
其它	散热方式	风冷 Air-cooling
	通讯接口	CAN/以太网/485/干接点

## 3. 电池系统设计及优势说明

### 3.1 方案概述

根据设计要求，系统容量为 215kWh。整体系统采用磷酸铁锂电池风冷户外柜的设计方案，户外柜内部配置电池、电池管理系统（BMS）、EMS、消防系统等辅助设备。



### 3.2 方案设计

- (1) 储能变流器配置 100kW，电池容量采用行业主流安全可靠的 280Ah，一簇 215.04kWh；
- (2) 系统采用交流耦合方案，业主可通过 EMS 系统匹配的云端功能进行系统的日常监控和控制，以达到系统的最高利用价值；
- (3) 采用户外一体柜布局，便于安装运输。

### 3.3 电池系统设计

本次系统设计采用的是磷酸铁锂电池，电池部分主要由电池正极、电池负极、电解质、隔膜、正极引线、负极引线、中心端子、PTC、电池壳体等部分组成。磷酸铁锂电池具备显著的应用优势，体积比同类电池更小，具备更大的能量密度，对环境友好无污染，使用过程无记忆效应。

在磷酸铁锂电池中，铁与锂在氧原子八面体中心位置，分别各自形成了  $\text{FeO}_6$  和  $\text{LiO}_6$  的八面体结构。 $\text{FeO}_6$  和  $\text{LiO}_6$  的排列形式交错相间，最终形成了层状脚手架的结构。磷酸铁锂正极材料的橄榄石结构稳定性更强，安全性更高，且具备良好的循环性能，尤其是高温循环性能。使用温度的提高能够使电池组高倍率放电性能增强，且具备很高的堆密度和体积能量密度。

### 3.3.1 电芯设计

该系统采用 3.2V/ 280Ah 方形铝壳电池，容量大，能量密度高，棱柱形结构，采用安全可靠、长寿命的磷酸铁锂材料，参数如下：

项目	参数	外观 (仅供参考)	
化学材料	LFP		
尺寸	~174*71.5*204mm		
重量	~5.50±0.15Kg		
容量	280 Ah		
能量密度	170Wh/kg 355Wh/L		
电压	3.2V		
电压范围	2.5-3.65V		
温度范围	充电: 0°C~60°C 放电: -30°C~60°C		
存储温度	-40°C~60°C		
存储湿度	≤90%RH		
内阻	≤0.25mΩ		
循环寿命	≥8000 次		25±2°C 初始夹紧力 300Kgf; 标准充放电测试@70%EOL, 25±2°C, 0.5P
认证	UL1973/UL9540A/IEC62619, GB/T36276		

### 3.3.2 电池 PACK 设计

1P20S 风冷电池插箱由 2 个 1P10S 电池模组、1 个 BMU、1 个风扇和若干线束等组成。电池管理单元是电池管理系统的最小插箱单元，电池管理单元由电源模块、单体采集模块、温度采样模块、通道切换模块、均衡控制模块、通讯模块、CPU 及其外围电路组成，实时测量单体电池电压、电池串总电压、外部工作电源电压、电池环境温度、均衡电压(过欠压保护)、均衡电流(充电/放电)，并能通过 CAN 通讯总线将实时监测数据主动上报给电池簇管理单元并接受电池簇管理单元控制指令，参数如下表：

项目	参数	外观 (仅供参考)
成组方式	1P20S	
主要部件	电芯、BMU、CCS	
尺寸	~880*465*232.5mm	
重量	~110kg	
容量	280Ah	
能量	17.92kWh	
电压	64VDC	
电压范围	50~72V	
运行倍率	0.5C	
存储温度	-30~60°C	
存储湿度	5%~95% RH	

### 3.3.3 电池簇

本方案储能系统的每个电池簇由 12 个电池插箱按 1P240S 的组合方式组成, 通过 1 个高压箱完成对电池簇的控制。高压箱内集成电池簇管理单元, 电池簇管理单元向下收集电池模组信息, 向上层 EMS 提供信息, 电池簇管理单元采集本簇电池电压电流温度等信息对电池簇进行保护以及控制, 为保证电池簇的安全运行。电池簇额定电压 768V, 额定能量 215.04kWh, 参数如下表:

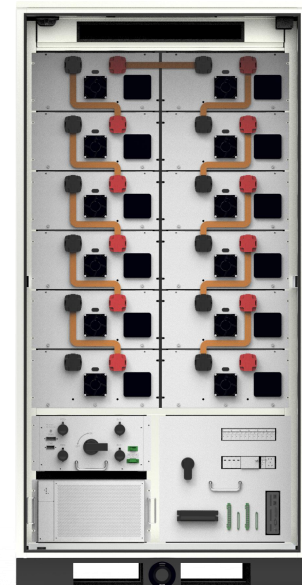
项目	参数	外观 (仅供参考)
成组方式	1P240S	
主要部件	PACK、高压箱	
重量	~1.71t	
容量	280Ah	
能量	215.04kWh	
电压	768VDC	
额定充放电电流	140A	
峰值电流	170A@60S	
风扇额定功耗	192W@24VDC	



### 3.3.4 电池管理系统

电池管理系统根据储能电池系统的成组方式相匹配与协调，采用分层的拓扑配置。上述包含电池模组、电池簇用二层架构的电池管理系统对电池运行状态进行优化控制及全面管理。在电池管理系统功能要求中，各功能具体实现层级由电池管理系统的拓扑配置情况决定，分层就地实现。

### 3.3.5 BMS 系统说明

储能系统电池管理系统采用电池管理单元 BMU、电池簇管理单元 BCMU 二级管理架构；BMU 从控模块采集电池插箱内电芯的电压、温度、单体 SOC、SOH 等数据，通过 CAN 网络传送给高压箱 BCMU 主控模块；高压箱内 BCMU 模块主要上传从控数据，控制高压箱内接触器的闭合/断开、检测簇电流、簇总电压等；BCMU 将簇内所有信息上传至 EMS；BCMU 负责与 PCS 通信、干接点输出等；BCMU 还负责与 EMS 通信，上送 BMS 相关信息；BMS 可实现对电池运行状态的优化控制及全面管理。

从控模块技术参数如下表所示：

序号	参数	单位	标准参数值
1	电压采样数量	串	24
2	温度采集数量	个	28
3	单体电压测量范围	V	0~5
4	电芯电压检测精度	mV	≤±3
5	电芯电压采样周期	ms	≤100
6	电芯温度检测范围	°C	-40~125
7	电芯温度检测精度	°C	≤2
8	电芯温度采样周期	ms	≤500
9	电池均衡方式	/	被动均衡
10	电池均衡电流	mA	100

11	通信方式	/	菊花链
----	------	---	-----

主控模块技术参数如下表所示：

序号 No.	参数	单位	标准参数值
1	总电压测量范围	V	50~1500
2	总电压测量精度	%	≤±0.5
3	总电压测量周期	ms	100ms
4	电流测量精度	%	0.5
5	电流测量周期	ms	50ms
6	SOC 计算	%	5
7	电能量计算误差	%	5
8	BCMU 供电	VDC	9~36
9	BCMU 功耗	W	2
10	工作温度范围	°C	-25~65
11	工作最大湿度	%	95
12	绝缘状态监控	/	有
13	温度检测范围	°C	-40~125
14	运行功耗	W	2
15	通信方式	/	CAN/Mod-bus
16	通信接口	/	CAN/485

### 3.4 户外柜设计

产品采用户外柜设计，户外柜内部集成电池簇、PCS、BMS、EMS、散热系统、消防系统等。户外柜防护等级为 IP54。

#### 3.4.1 户外柜

户外柜良好的防腐、防火、防水、防尘（防风沙）、防震、防紫外线、防盗等功能，保证 10 年内不会因腐蚀、防火、防水、防尘和紫外线等因素出现故障。

其中，防腐功能保证 10 年内户外柜的外观、机械强度、腐蚀程度等满足实际使用的要求；防火功能保证户外柜外壳结构、隔热保温材料、内外部装饰材料等全部使用阻燃材料；防水功能保证箱体顶部不积水、不渗水、不漏水，箱体侧面不进雨，箱体底部不渗水；防尘（防风沙）功能保证在户外柜在遭遇大风扬沙天气时可以有效阻止灰尘进入户外柜内部；防震功能保证运输和地震条件下户外柜及其内部设备的机械强度满足要求，不出现变形、功能异常、震后不运行等故障；防紫外线功能保证户外柜内外材料的性质不会因为紫外线的照射发生劣化、不会吸收紫外线的热量等。

户外柜外皮喷涂均一颜色，色号为 RAL7035，其外观 logo 可根据客户需求制定。在项目所在地的实际环境条件下，经历 10 年的综合腐蚀后，户外柜结构和支撑结构的技术性能满足初始供货时的力学性能要求。（户外柜的具体参数根据业主下单后项目地的环境情况细化）

#### 3.4.2 散热系统设计

依据整个储能系统运行工况，分析整个系统的制冷制热需求，进行合理的系统布置和空调机组及管路的选型、热管理控制策略等热管理系统设计工作。

通过热管理系统，保证电池在充电、放电和静置各阶段，本体温度均在  $0^{\circ}\text{C} \sim 40^{\circ}\text{C}$  范围内。户外柜温度控制系统是由 1 台 5kW 的空调及风道组成，可实现户外柜内部的制冷和加热。控制系统根据室内外温度、湿度自动控制温控系统的工作，保障箱内的电池设备工作于  $0^{\circ}\text{C} \sim 40^{\circ}\text{C}$  温度范围的工况。

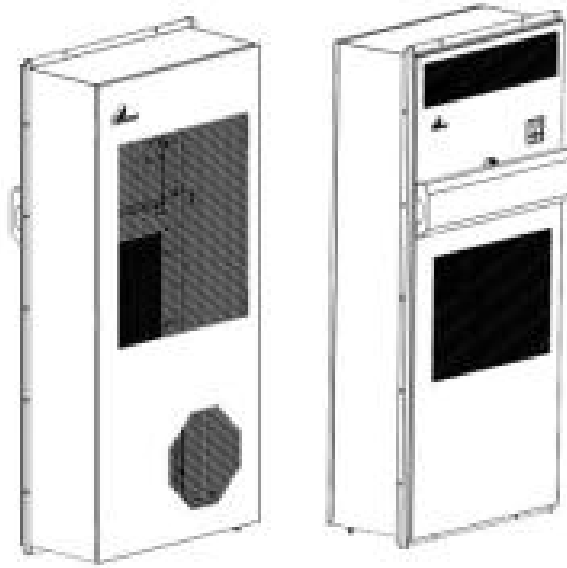

### 3.4.3 消防系统设计

灭火装置是一种新型 S 型热气溶胶灭火装置，是一类具有超高灭火效能和可靠性的消防领域突破性产品，该产品有体积小巧、无压存储、无需铺设管网和维护、灭火高效、迅速、无毒无害、安全可靠、绿色环保等特点。一般灭火剂的灭火机理主要有隔离法、窒息法、冷却法、化学抑制法，不同的灭火剂具有不同的灭火机理。热气溶胶的灭火机理主要体现在两方面：一方面是吸热分解的降温作用，另一方面是气相、固相的化学抑制作用，相互之间协同发挥。除此之外气溶胶灭火剂产物中的气相成分也起到了一定的辅助作用。

当火灾发生时，灭火装置在接收到电启动信号后或明火引燃热敏线，电引发器或热敏线燃烧激活灭火装置内的气溶胶发生剂，气溶胶发生剂通过氧化还原反应释放的热量使化学冷却剂分解，实现气溶胶发生剂和冷却剂共同参与灭火。

### 3.4.4 配电系统及接地设计

系统配置了模块化式的配电模块，集成了输入断路器、电能表、SPD、配电断路器等元器件，用户只需将交流电接至输入端即可进行开机操作，使得整机相对清晰整洁。

户外柜以铜排及接地螺柱的形式向用户提供 2 个符合电力标准要求的接地点，向用户提供的接地点

与整个户外柜的非功能性导电导体形成可靠的等电位连接，接地点应位于户外柜的内部及基座位置。

### 3.4.5 储能变流器

PCS 模块采用模块化设计，具备恒压、恒流、恒功率模式，支持离网、并网运行，并可在多种模式之间智能切换，同时兼具无功补偿及谐波补偿功能。采用先进控制算法实现多机并联，具备优良的负载适应性和电网适应性。

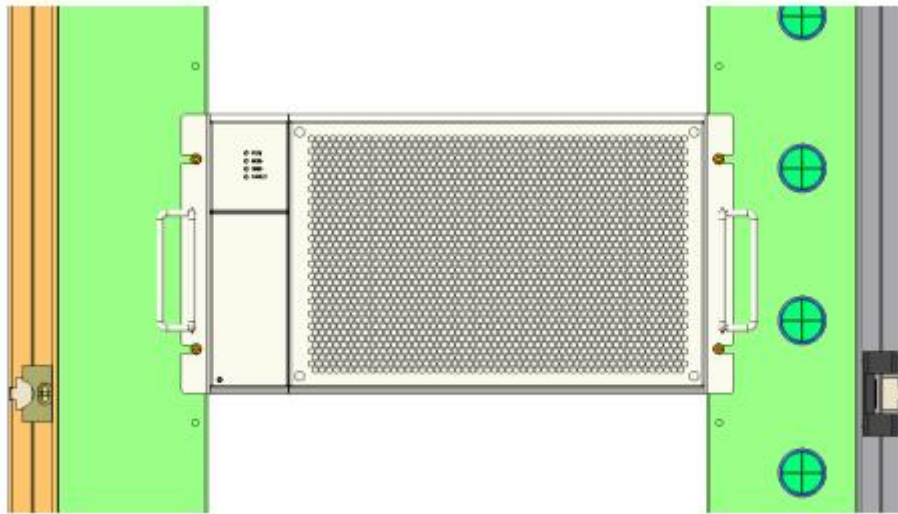

- a) 交直流取电，支持黑启动；
- b) 能量双向流动，正反向无缝切换，满载切换时间低至 30ms；
- c) 高可靠防护性能，耐高低温，潮湿，盐雾等恶劣环境；
- d) 较宽的工作温度范围：-30°C ~ 60°C；
- e) 三相 100%不平衡带载，支持接入单相载，负载配置灵活。

储能变流器技术参数

直流侧	
额定电压	800VDC
电压范围	670~1000VDC
最大充/放电电流	165A

交流侧并网	
最大输入视在功率	110kVA
最大输入有功功率	110kW
额定输入电压	400VAC, 3P+N+PE
最大持续输入电流	158A
额定输入频率	50Hz
功率因数	0.8cap~0.8ind
交流侧离网	
额定输出电压	400Vac, 3P+N+PE
额定输出频率	50/60Hz
最大持续输出电流	158A
最大输出有功功率	110kW
最大输出视在功率	110kVA
不平衡负载能力	100%
过载能力	1.1 倍 10mins@35°C (环温) ; 1.2 倍 1min
通用参数	
工作温度范围	-30 ~ 60°C (> 45°C降额)
工作海拔高度	~3000m
最大效率	98.5%
交直流启动功能	是
尺寸 (长*宽*高)	~490mm*654mm*248mm
重量	~50kg

#### 4. 系统一次拓扑图

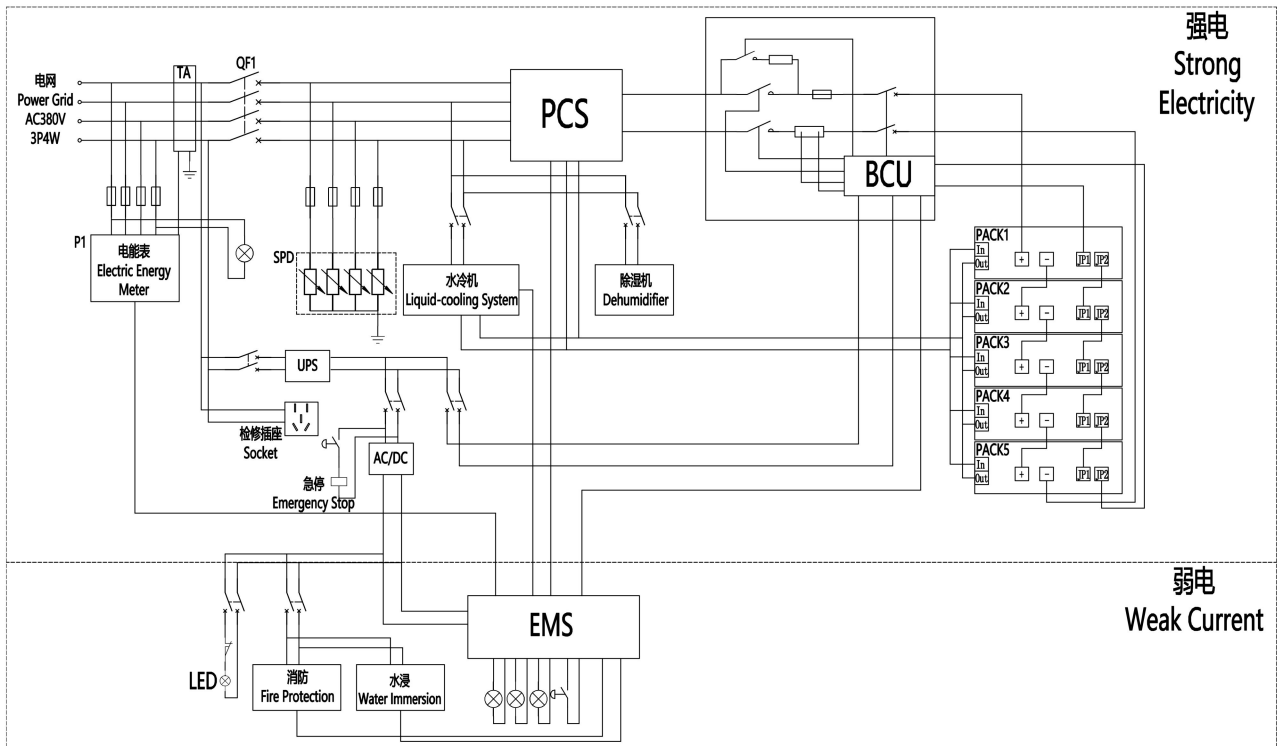

# PRODUCT SPECIFICATION

Product Name:

**RE-D705 Air-cooling Outdoor Cabinet**

Product Model No.:

***REMAW07680280C03AV02***

Date: 25/01/2024

APPROVER	AUDITOR	EDITOR	Version No.



## CONTENT

1. Overview .....	18
1.1. Design Principle .....	18
1.2. Reference Standard .....	18
2. System Design .....	18
2.1. System Composition .....	18
2.2. System Parameter .....	19
3. Battery System Design and Advantage Description .....	20
3.1 Scheme Overview .....	20
3.2 Scheme Design .....	20
3.3 Battery System Design .....	21
3.3.1 Battery Design .....	21
3.3.2 Battery Pack Design .....	22
3.3.3 Battery Rack .....	23
3.3.4 BMS .....	23
3.3.5 BMS Description .....	24
3.4 Outdoor Cabinet Design .....	26
3.4.1 Outdoor Cabinet .....	26
3.4.2 Cooling System Design .....	27
3.4.3 Fire-fighting System Design .....	28
3.4.4 Distribution System and Ground Connector Design .....	28
3.4.5 Power Conversion System .....	29
4. Primary Topological Graph of System .....	31

## 1. Overview

### 1.1. Design Principle

- (1) Use mature technology and processing technique;
- (2) Products conforming to relevant national and energy storage standards;
- (3) Products satisfying the indexes of technical performance;
- (4) Follow standardized, modular and universal design principle, making sure the universality and interchangeability of product.

### 1.2. Reference Standard

GB/T 36276-2018	Lithium ion battery for electrical energy storage
GB/T 36558-2018	General technical requirements for electrochemical energy storage system in power system
GB/T 34131-2023	Battery management system for electrical energy storage

## 2. System Design

### 2.1. System Composition

According to the requirements of product design, system is composed of 100kW PCS, 215kWh battery cluster, 5kW air-conditioning and aerosol fire-fighting system. Also, it is equipped with SPD and water-logging protection, which can realize the functions of peak-load shifting, demand control and backflow prevention.

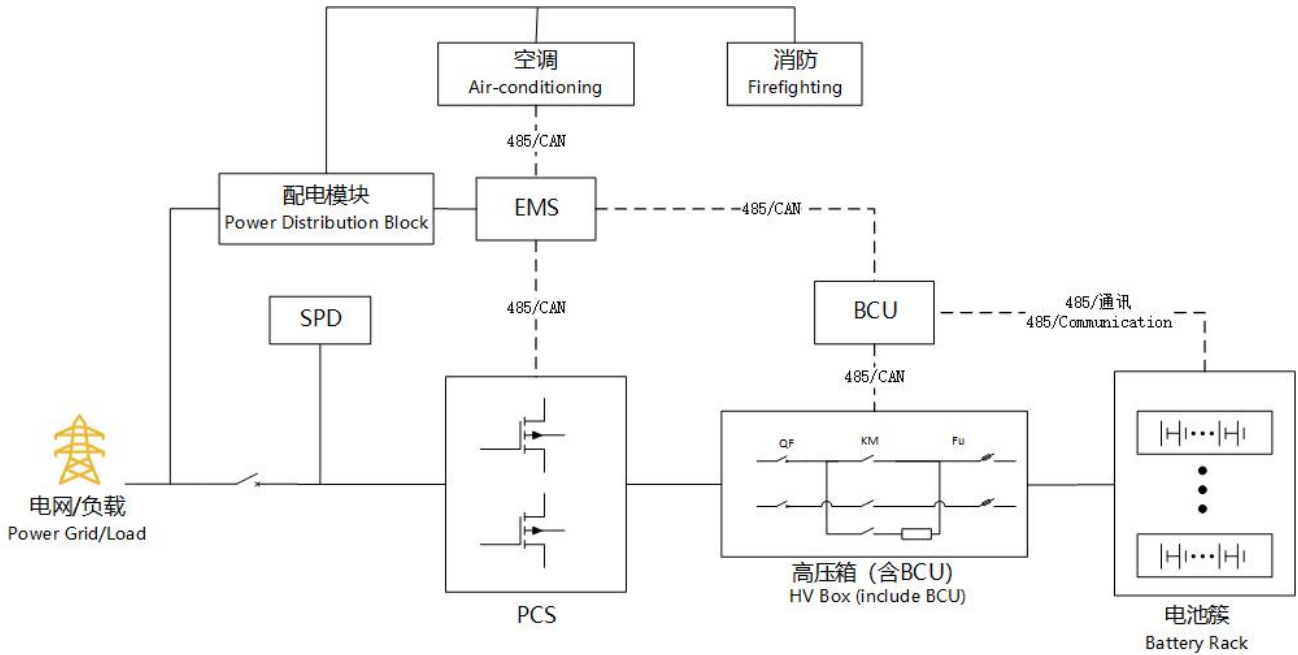

## 2.2. System Parameter

DC Parameters	System Capacity	215kWh
	Battery Capacity	280Ah (LFP)
	System Configuration	1P240S
	Rated Voltage	768VDC
	DC Voltage Range	672VDC~864VDC
	Charging/discharging Rate	0.5P
AC Parameters	Rated Power	100kW
	Rated Voltage	380V, -15%~10%
	Accessing Method	3P4W+PE
	Rated Frequency	50/60Hz
	Power Factor	0.8cap~0.8ind
	Thdi	≤3% (rated power)
Efficient Rate		Max. 98.5%
Protection	AC Side	Moulded Case Circuit Breaker
	DC Side	Disconnecter+Fuse
	Fire-fighting	Aerosol+Water Fire-fighting
Environmental Condition	Working Temperature	-25~60°C (>45°C derating)
	Altitude	≤2000m
	Relative Humidity	0~100%
Physical Feature	Weight	~2t
	Dimension (L*W*H)	~1170mm*1420mm*2365mm
	IP Level	IP54

Others	Cooling Method	Air-cooling
	Communication Access	CAN/Ethernet/485/Dry Contact

### 3. Battery System Design and Advantage Description

#### 3.1 Scheme Overview

According to the requirements of design, the system capacity is 215kWh. The whole system uses the design scheme of LFP battery air-cooling outdoor cabinet equipped with batteries, BMS, EMS, fire-fighting system and other auxiliary equipment.

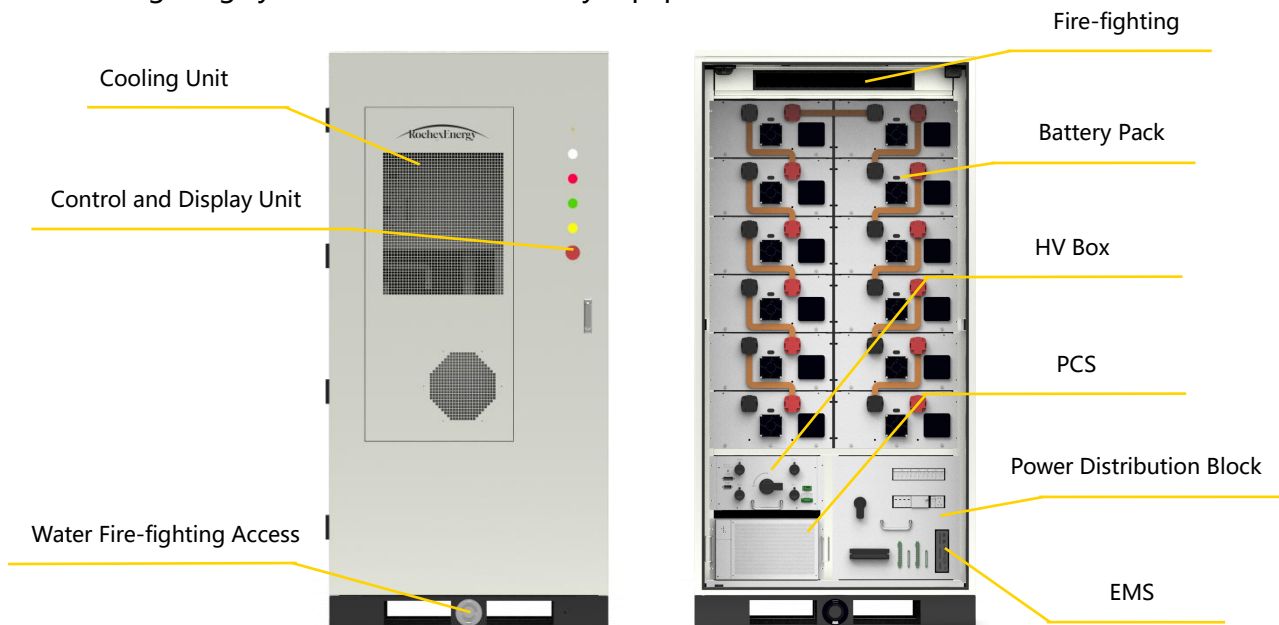

#### 3.2 Scheme Design

- (1) Equipped with 100kW PCS, mainstream, safe and reliable 280Ah battery, and 215.04kWh per battery cluster;
- (2) System uses AC coupling scheme, clients can monitor and control the system on daily base by using the cloud function of EMS in order to optimize the use value of system
- (3) Use all-in-one outdoor cabinet design for easy installation and transport.

### 3.3 Battery System Design

System design uses LFP battery which is composed of cathode, anode, electrolyte, diaphragm, positive electrode lead, negative electrode lead, center terminal, PTC, battery shell and other parts. LFP battery has obvious advantages in use, smaller volume and higher energy density than other like products, no pollution to environment and no memory effect during using process.

In LFP battery, Fe and Li form  $FeO_6$  and  $LiO_6$  octahedral structure respectively at the center position of octahedral oxygen atom. The arrays of  $FeO_6$  and  $LiO_6$  interlace with one another and finally form to be the lamellate scaffold structure. Olivine structure of LFP anode material is much more stable and safer with good cycle performance, especially in high temperature environment. Increase in temperature during using process can strengthen the discharge performance of batteries at high rate with high bulk density and volume energy density.

#### 3.3.1 Battery Design

The system uses 3.2V/ 280Ah rectangular aluminum-shell battery from BatteroTech which has larger capacity, higher energy density with prismatic structure and uses safe, reliable and long-life LFP materials. Its parameters are showed as below:

Item	Parameters	Appearance (for reference only)
Chemical Materials	LFP	
Dimension (L*W*H)	~174*71.5*204mm	
Weight	~5.50±0.15Kg	
Capacity	280 Ah	
Energy Density	170Wh/kg 355Wh/L	
Voltage	3.2V	
Voltage Range	2.5-3.65V	
Temperature Range	Charge: 0°C~60°C Discharge: -30°C~60°C	
Storage Temperature	-40°C~60°C	

Storage Humidity	≤90%RH	
Internal Resistance	≤0.25mΩ	
Cycle Life	≥8000 times	25±2°C initial clamp force is 300Kgf; Standard charging/discharging test@70%EOL, 25±2°C, 0.5P
Certification	UL1973/UL9540A/IEC62619, GB/T36276	

### 3.3.2 Battery Pack Design

1P20S air-cooling battery pack is composed of two 1P10S battery modules, a BMU, a fan and some cable wires. Battery Management Unit (BMU) is the smallest unit in Battery Management System (BMS). BMU is composed of power module, monomer acquisition module, temperature sampling module, channel switching module, balance control module, communication module, CPU and other external circuits. Also, BMU can test single battery voltage, total voltage of battery series, external working power voltage, environmental temperature of battery, equalizing voltage (Over-voltage and under-voltage protections) and equalizing current (charge/discharge) in real time. Through CAN communication bus, it can report real-time data to Battery Cluster Management Unit (BCMU) actively and accept the control command from BCMU. Its parameters are showed as below:

Item	Parameters	Appearance (for reference only)
Configuration	1P20S	
Main Components	Battery cell, BMU, CCS	
Dimension (L*W*H)	~880*465*232.5mm	
Weight	~110kg	
Capacity	280Ah	
Energy	17.92kWh	
Voltage	64VDC	
Voltage Range	50~72V	
Working Rate	0.5C	
Storage Temperature	-30~60°C	
Storage Humidity	5%~95% RH	

### 3.3.3 Battery Rack

Battery rack in the Energy Storage System (ESS) is composed of 12 battery packs, formed as the way of 1P240S and controlled by a HV box. There is an integrated BCMU, inside of HV box, which not only collects information downwards from battery modules and reports it upwards to EMS, but also gathers voltage, current, temperature and other information from batteries in order to protect and control the battery rack for guaranteeing its safe operation all the time. The rated voltage and energy of battery rack are 768V and 215.04kWh respectively. Its parameters are showed as below:

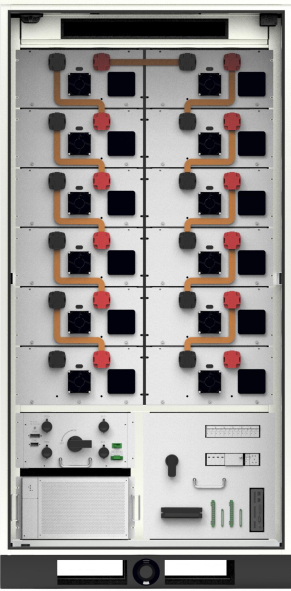
Item	Parameters	Appearance (for reference only)
Configuration	1P240S	
Main Components	Pack and HV box	
Weight	~1.71t	
Capacity	280Ah	
Energy	215.04kWh	
Voltage	768VDC	
Rated Charging/Discharging Current	140A	
Peaking Current	170A@60S	
Rated Power Dissipation of Fan	192W@24VDC	

### 3.3.4 BMS

BMS pairs and coordinates correspondingly to the grouping method of BESS (Battery Energy Storage System), and uses topological configuration. The BMS which uses two-tier structure including battery modules and battery rack can optimize, control and manage thoroughly

operational status of battery. According to the requirements of BMS function, the realization sequence of each function is decided by topological configuration of BMS and each function will be realized one by one according to the sequence.

### 3.3.5 BMS Description

BMS in the ESS includes BMU and BCMU which is secondary management structure. BMU collects voltage, temperature, monomer SOC, SOH and other information from battery inside of battery pack, and uploads these data to BCMU in the HV box through CAN. BCMU inside of HV box mainly uploads slave control data, controls the close and break of contactor inside of HV box and detects the current, total voltage and other data of battery rack. BCMU is responsible for uploading all information relevant to battery rack to EMS, communicating with PCS, dry contact output and sending relevant information of BMS to EMS. BMS can realize the optimization, control and thorough management of battery operational status.

Technical Parameters of Slave Control Module are showed in the table below:

No.	Parameter	Unit	Standard Parameter Value
1	The collecting number of voltage	Series	24
2	The collecting number of temperature	PCS	28
3	The testing range of monomer voltage	V	0~5
4	The detecting accuracy of battery voltage	mV	$\leq \pm 3$
5	The collecting period of battery voltage	ms	$\leq 100$
6	The detecting range of battery temperature	°C	-40~125
7	The detecting accuracy of battery temperature	°C	$\leq 2$
8	The collecting period of battery temperature	ms	$\leq 500$



9	The equalized method of battery	/	Passive equalization
10	The balance current of battery	mA	100
11	Communication method	/	Daisy chain

Technical Parameters of Master Control Module are showed in the table below:

No.	Parameter	Unit	Standard Parameter Value
1	The testing range of total voltage	V	50~1500
2	The testing accuracy of total voltage	%	≤±0.5
3	The testing period of total voltage	ms	100ms
4	The testing accuracy of current	%	0.5
5	The testing period of current	ms	50ms
6	SOC calculation	%	5
7	Calculation error of electric energy	%	5
8	BCMU power supply	VDC	9~36
9	BCMU power dissipation	W	2
10	Working temperature range	°C	-25~65
11	Max. Working humidity	%	95
12	Monitoring of insulation status	/	Yes
13	The detecting range of temperature	°C	-40~125
14	Operational power dissipation	W	2
15	Communication method	/	CAN/Mod-bus
16	Communication access	/	CAN/485

### 3.4 Outdoor Cabinet Design

The product use outdoor cabinet design, and there are battery rack, PCS, BMS, EMS, cooling unit, fire-fighting system and others integrated together in its interior. Also, the IP level of outdoor cabinet is IP54.

#### 3.4.1 Outdoor Cabinet

Outdoor Cabinet has a number of significant functions, such as anti-corrosion, fireproof, waterproof, dust prevention (sand proof), quake-proof, ultraviolet-proof, anti-theft and so on, ensuring the product will not malfunction due to corrosion, fire, water, dust, ultraviolet and other similar reasons in 10 years.

Among these functions, anti-corrosion can guarantee the appearance of outdoor cabinet, mechanical strength and the extent of corrosion can satisfy the requirements in actual use. Fire-proof function means the cabinet structure, thermal insulation materials and decorative materials are all flame-retardant. Waterproof function ensures that there are no water, water seepage and water leak on the top of cabinet, no rain leaking from the sides of cabinet, and no water leak on the bottom of cabinet. Dust prevention (sand proof) function guarantees the effectiveness of preventing dust from the exterior of outdoor cabinet when there is gale and sand storm. Quake-proof function guarantees that the mechanical strength of outdoor cabinet and its internal equipment satisfies the requirements of no deformation, malfunction and abnormal operation when it is during the transportation and earthquake. Ultraviolet-proof ensures the materials of outdoor cabinet will not be damaged by ultraviolet irradiation and absorb the heat of ultraviolet.

The outdoor cabinet is painted by color of RAL7035 with a customized logo. Under the actual

condition of project location, the structure of outdoor cabinet and technical performance of support construction can satisfy requirements of initial mechanical property at the time of product delivery. (the detailed parameters of outdoor cabinet will be decided according to the environmental condition of project location after clients place the order to our company)

### 3.4.2 Cooling System Design

According to the whole ESS operational status, through analyzing the cooling and heating requirements of whole system, the thermal management system is designed with reasonable system configuration, air-conditioning, pipeline, and thermal management and control strategy.

Thermal management system can guarantee battery temperature at the range of 0°C to 40°C during the stages of charging, discharging and static state. The temperature control system of outdoor cabinet is composed of a 5kW air-conditioning and air duct, which can cool and heat the interior of outdoor cabinet. The control system manipulates automatically the work of temperature control system according to outdoor/indoor temperature and humidity, guaranteeing the working temperature of internal battery equipment is between 0°C and 40°C.

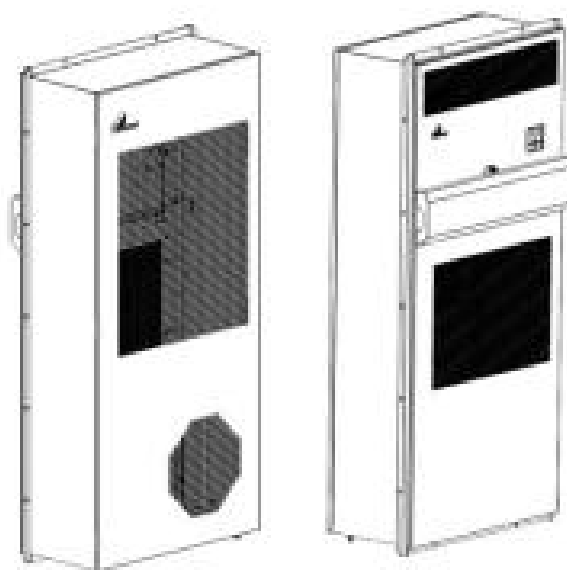

### 3.4.3 Fire-fighting System Design

Fire extinguishing equipment is a new S type condensed aerosol which is a breakthrough product in fire protection field with ultrahigh fire-fighting efficiency and reliability. It has the features of small volume, unpressurized storage, no need of pipeline and maintenance, high efficiency of fire extinguishing, quick start, non-toxic and no harm, safety and reliability, environmental-friendly and so on. Fire-fighting principles of normal extinguishing agents have isolation, smothering, cooling and chemical suppression method, which means different extinguishing agents have different fire-fighting principles. The fire-fighting principles of condensed aerosol are mainly showed at two aspects, the one is absorbing heat to cool down the temperature, and the other aspect is chemical suppression effects of gaseous and solid phase which can work coordinately with each other. Besides, the ingredient of gaseous phase in aerosol has certain auxiliary effect on fire extinguishing.

When fire occurs, electric initiator or burning thermosensitive cable activates aerosol in the fire-extinguishing equipment after fire-extinguishing equipment receives signal of electric initiator or fire burns thermosensitive cable. Aerosol releases heat through redox reaction to decompose the chemical coolant, which realizes aerosol and coolant extinguish fire together at the same time.

### 3.4.4 Distribution System and Ground Connector Design

The system is configured the modular power distribution block and integrated with input circuit breaker, SPD and distributor breaker. For starting the operation, clients only need to connect AC to input terminal, which is showed clearly on the machine and easy to manipulate.

Clients are provided two grounding points which use the way of copper bar and grounding

stud on the outdoor cabinet and are conformed to electric power standard as well. The grounding points provided to clients are formed a reliable equipotential connection with non-functional electric conductor of outdoor cabinet. The positions of grounding points are in the interior of the cabinet or on its bottom base.

### 3.4.5 Power Conversion System

PCS uses modular design with the modes of constant voltage, current and power, supports off-grid and grid-connected operation, and can switch modes between many different types intelligently. At the meantime, it has the functions of reactive and harmonic compensations. Using the leading control calculation realizes multi-machine parallel connection, which has good adaptation to load and power grid.

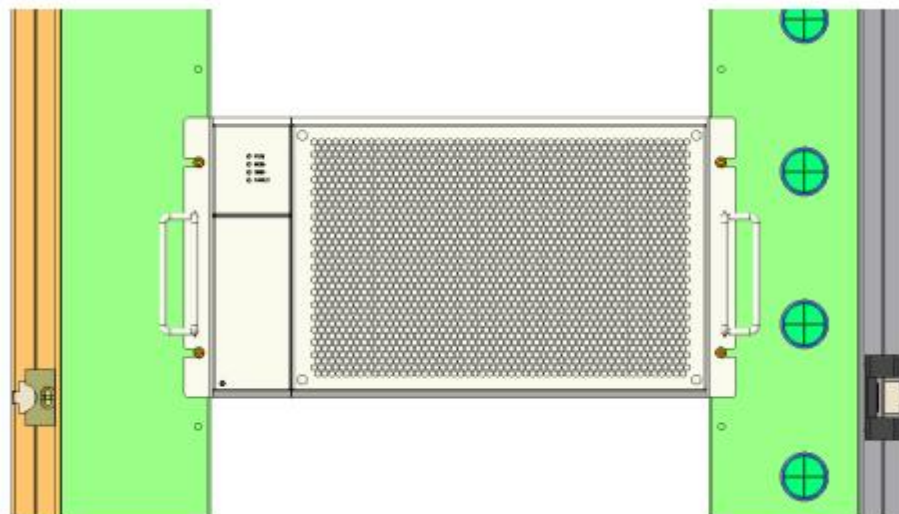

- a) Supply electricity through AC/DC, support black start;
- b) Energy flows bi-directionally, forward and reverse directions are switched seamlessly, and the switching time of full load is lower to 30ms
- c) High reliable and protective performance, tolerant to high and low temperature, humidity, salt fog and other extremely severe environment;

- d) The range of working temperature is quite big, which is between  $-30^{\circ}\text{C} \sim 60^{\circ}\text{C}$ ;
- e) Three phase 100% imbalance with load, support to connect single-phase load, the load configuration is flexible.

#### Technical Parameters of PCS

DC Side	
Rated Voltage	800VDC
Voltage Range	670~1000VDC
Max. Charging/Discharging Current	165A
AC Side (grid-connected)	
Max. Input Apparent Power	110kVA
Max. Input Active Power	110kW
Rated Input Voltage	400VAC, 3P+N+PE
Max. Continuous Input Current	158A
Rated Input Frequency	50Hz
Power Factor	0.8cap~0.8ind
AC Side (off-grid)	
Rated Output Voltage	400Vac, 3P+N+PE
Rated Output Frequency	50/60Hz
Max. Continuous Output Current	158A
Max. Output Active Power	110kW
Max. Output Apparent Power	110kVA
Imbalance Load Capacity	100%

Overload Capacity	1.1 times 10mins @ 35°C (environmental temperature); 1.2 times 1min
Common Parameters	
Working Temperature Range	-30 ~ 60°C (> 45°C derating)
Altitude	~3000m
Max. Efficiency	98.5%
AC/DC Start Function	是 Yes
Dimension (L*W*H)	~490mm*654mm*248mm
Weight	~50kg

#### 4. Primary Topological Graph of System

